

Introduction to MIMO Radar Waveforms

Hongbo Sun

Institute for Infocomm Research

Agency for Science, Technology and Research (A*STAR), Singapore

ARES PUBLIC

Introduction of MIMO Radar

ARES PUBLIC



Statistical MIMO Radar v.s. Coherent MIMO Radar

MIMO radar with widely separated antennas
(Statistical MIMO radar)

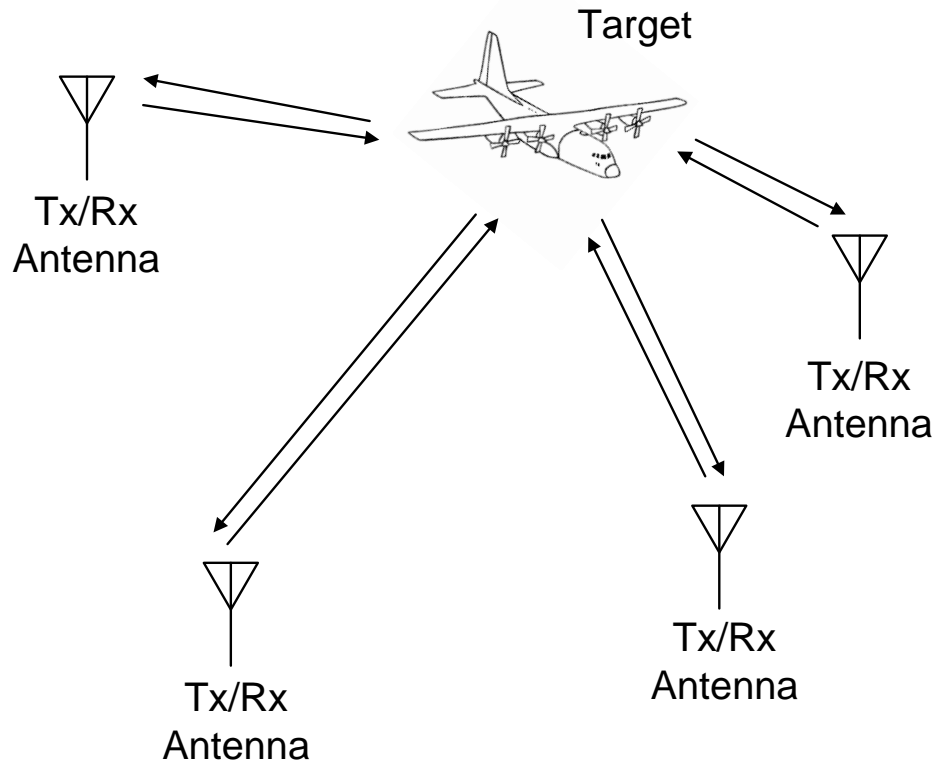

- Diversity gain to overcome the RCS fading and achieve more robust detection performance

MIMO radar with co-located antennas
(Coherent MIMO Radar)

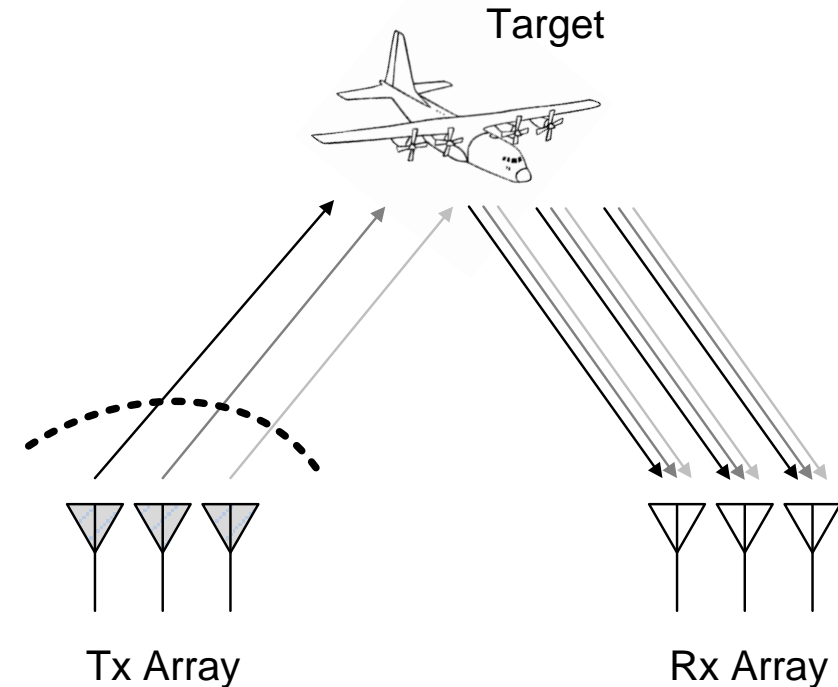

- Flexibility of extending array aperture (in 1D or 2D) with less number of Tx/Rx elements

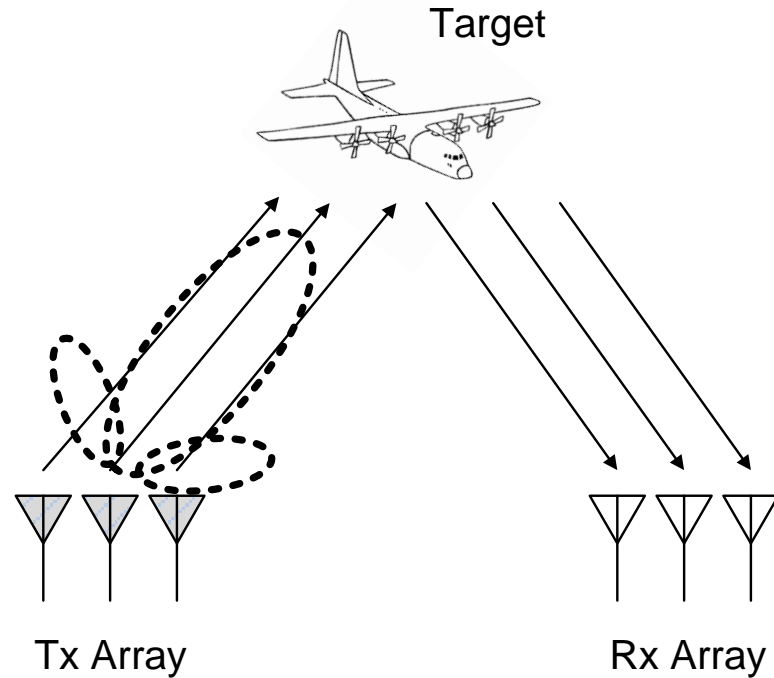

Coherent MIMO Radar v.s. Phased Array Radar

Phased Array Radar

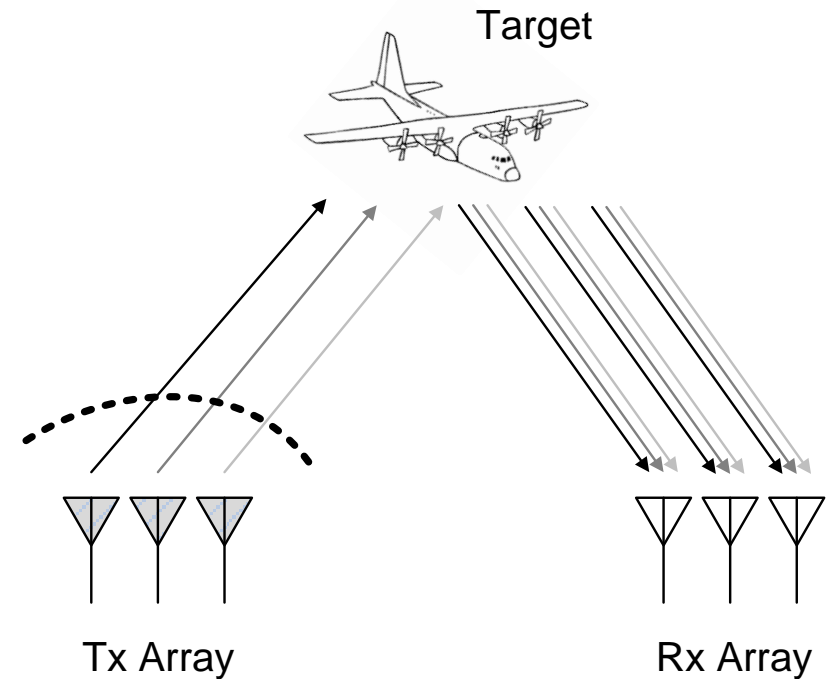

Coherent MIMO Radar



- Loss of transmit array gain 
- Continuous illumination with longer coherent integration gain 

Virtual Aperture of MIMO Radar

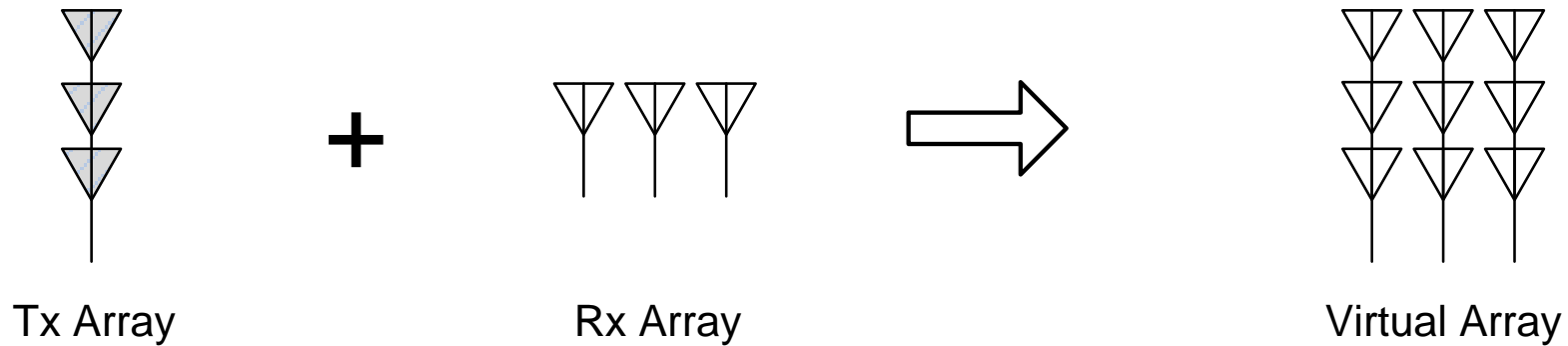
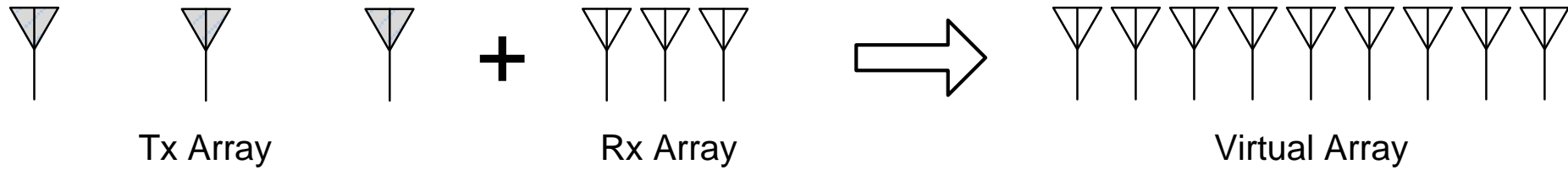

Virtual array formed by different MIMO configurations

Typical MIMO Radar Waveforms

(TDMA, DDMA, CDMA, FDMA, Hadamard coding, circulating waveforms)

ARES PUBLIC

Time Division Multiple Access (TDMA) Waveform – Alternative Transmission

- Easy to implement and with almost ideal orthogonality.
- **Cannot make full use of Tx resource.**

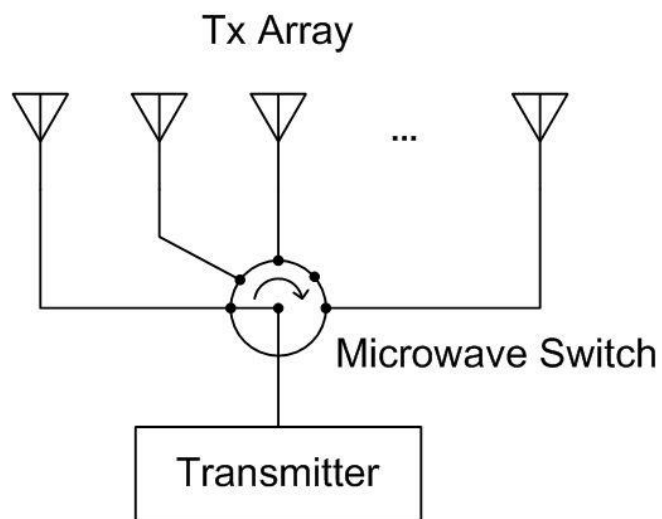

Example: MIMO-SAR imaging (FHR, Germany)

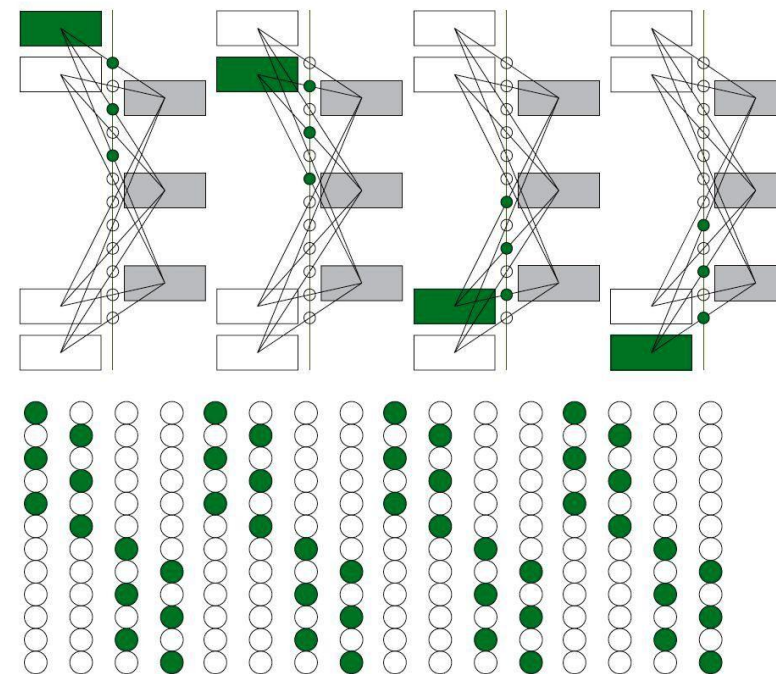
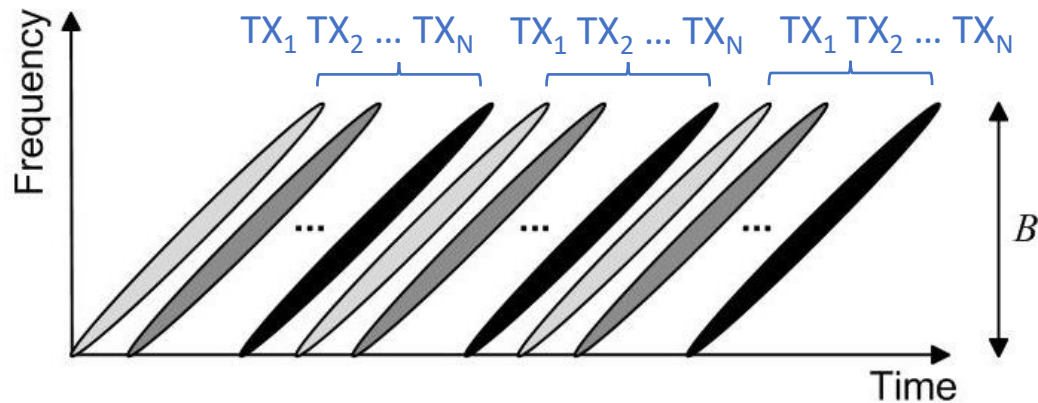

Fig. 3. Tx switching and the resulting synthetic array

[Ref] J.H.G. Ender, J. Klare, "System architectures and algorithms for radar imaging by MIMO-SAR", 2009 IEEE International Radar Conference, Pasadena, CA, USA, May 2009

Time Division Multiple Access (TDMA) Waveform – Time Staggered FMCW

- Almost ideal orthogonality.
- Only applicable to low frequency radar with enough PRF tolerance.



Example: HF over-the-horizon radar (DSTO, Australia)

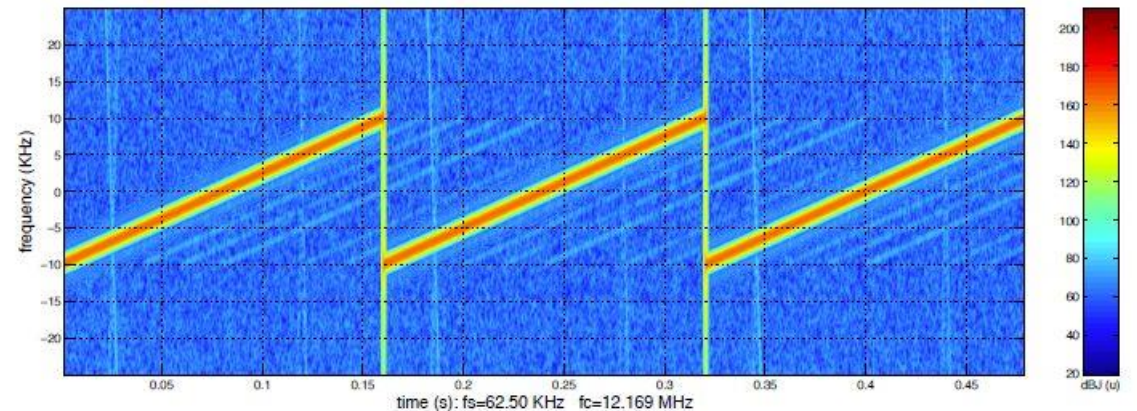

Fig. 3. Spectrogram of the output of one waveform generator and high power amplifier for the case of a staggered linear FMCW waveform set. The signal shown corresponds to one member of the waveform set and is the signal radiated from one transmit array element.

[Ref] G. J. Frazer, Y. I. Abramovich, B. A. Johnsonz, and F. C. Robeyx, "Recent Results in MIMO Over-the-Horizon Radar", 2008 IEEE Radar Conference, Rome, Italy, May 2008, pp.789-794

Doppler Division Multiple Access (DDMA) Waveform

- Linear phase ramps are applied to the pulse trains of different transmit antennas to produce different Doppler offsets.
- Almost ideal orthogonality.
- Only applicable to low frequency radar with enough PRF tolerance.

Example: Airborne GMTI radar (MIT Lincoln Laboratory)



MIMO Array Configuration

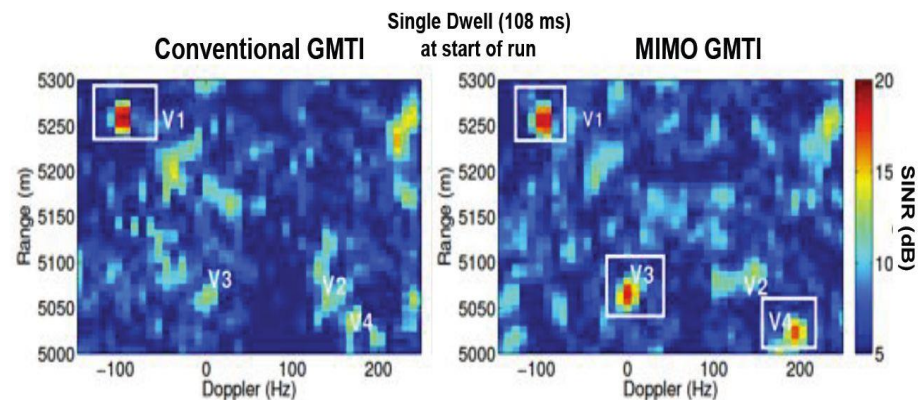
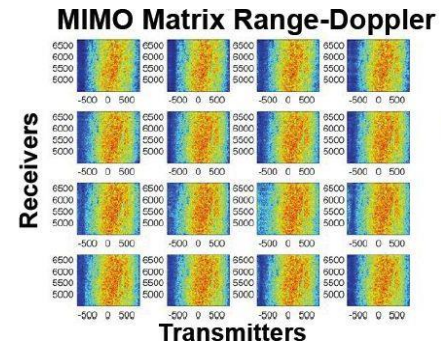
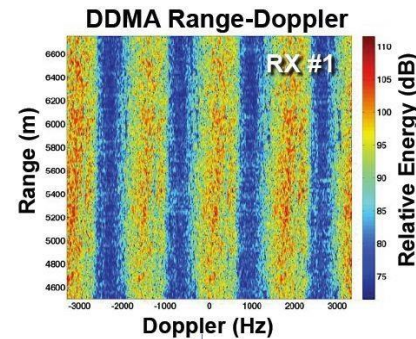
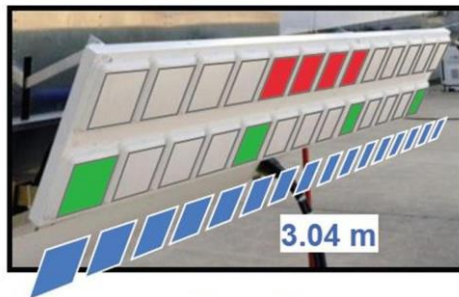

[Ref] J. Kantor, S.K. Davis, "Airborne GMTI using MIMO techniques", 2010 IEEE International Radar Conference, Washington D.C., US, pp.1344-1349, May 2010

Doppler Division Multiple Access (DDMA) Waveform

The instantaneous beam patterns of DDMA waveform

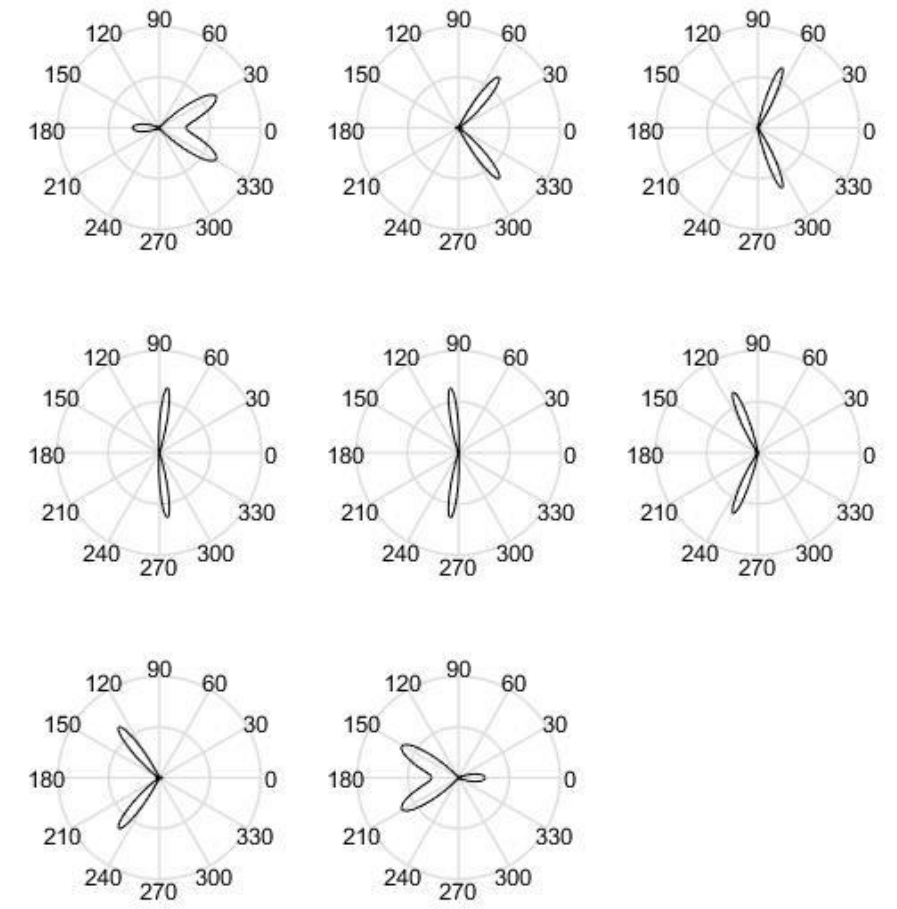
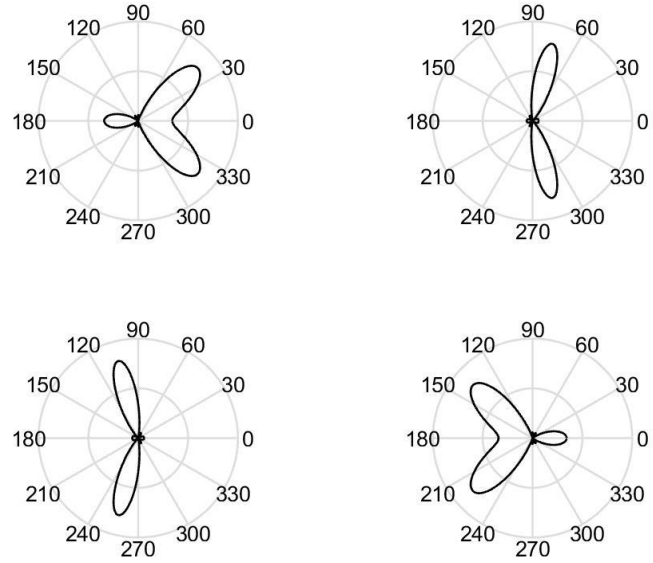
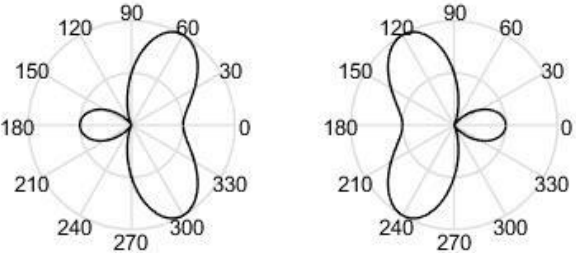

2 Tx with normalized Doppler offsets [-0.25, 0.25]

4 Tx with normalized Doppler offsets [-0.375, -0.125, 0.125, 0.375]

8 Tx with normalized Doppler offsets [-0.4375, -0.3125, -0.1875, -0.0625, 0.0625, 0.1875, 0.3125, 0.4375]

Simulation Parameters

4x4 MIMO Radar Configuration:

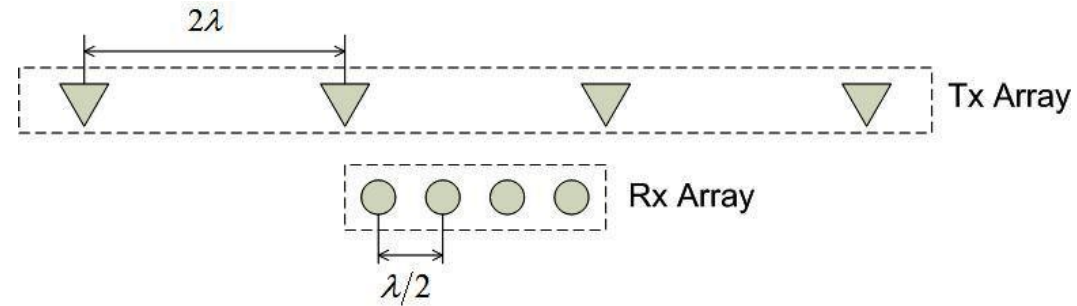

MIMO radar parameters in simulations

Carrier Frequency	35 GHz	Pulse Width	1 μ s
No. of Transmitting Antennas	4 (two-wavelength interelement spacing)	Pulse Repetition Interval (PRI)	10 μ s
No. of Receiving Antennas	4 (half-wavelength interelement spacing)	Pulse Repetition Frequency (PRF)	100 kHz
Array Configuration	Co-linear	Duty Cycle of Pulse	10%
Total signal bandwidth	500 MHz	Coherent Integration Time	2 ms

Target parameters in simulations

Range	500 m	Angle	90° (array boresight)
Radial Velocity	10 m/s	Doppler Frequency	2.333 kHz

Doppler Division Multiple Access (DDMA) Waveform

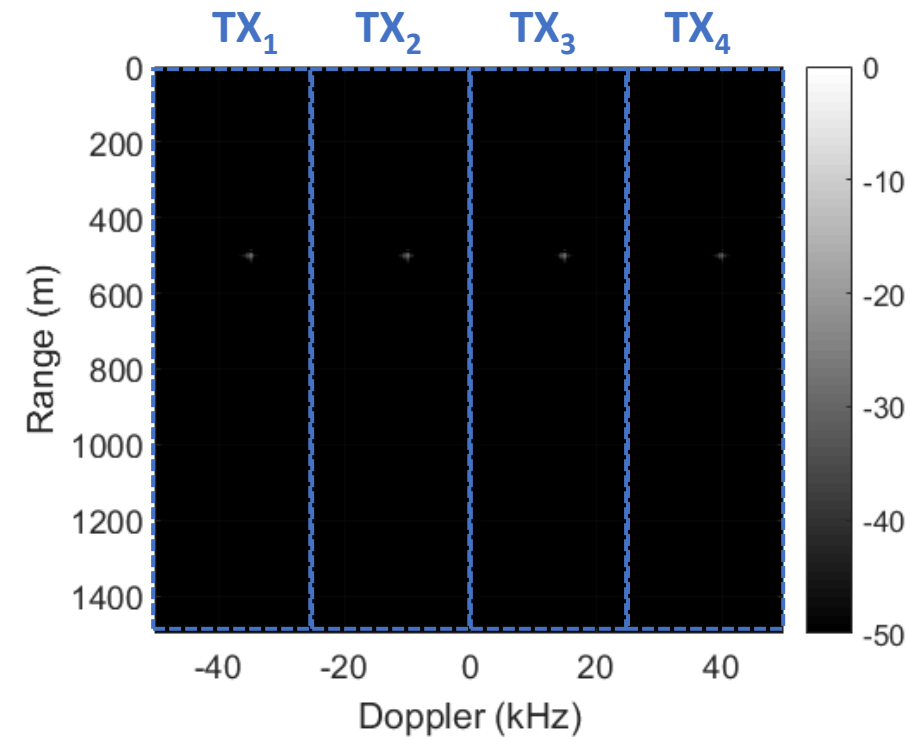

Range-Doppler plot of DDMA data received by one antenna

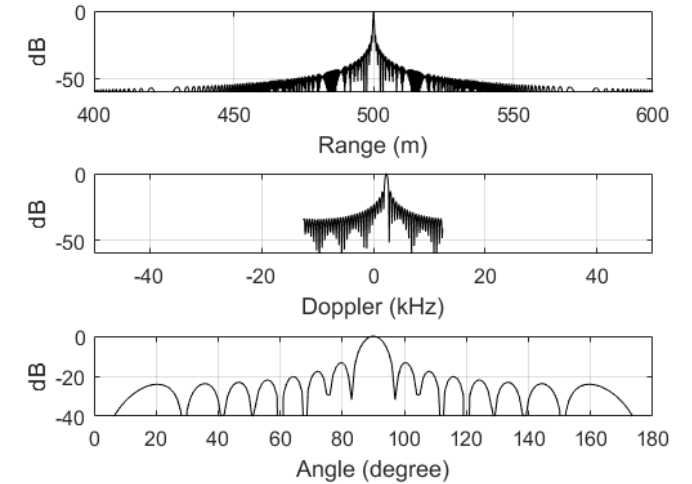
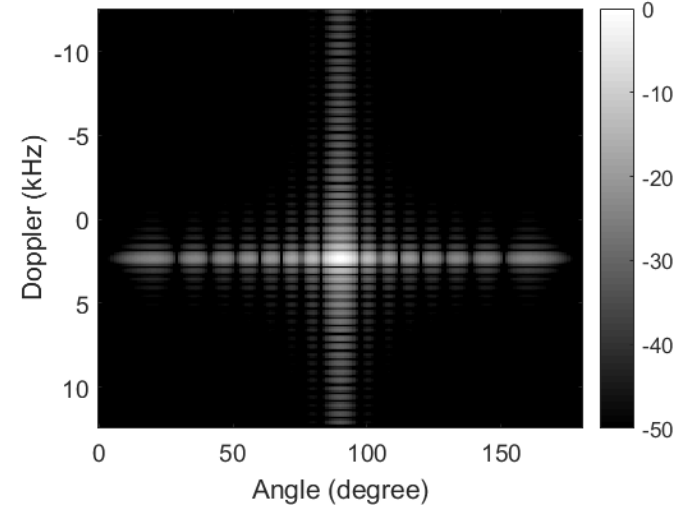
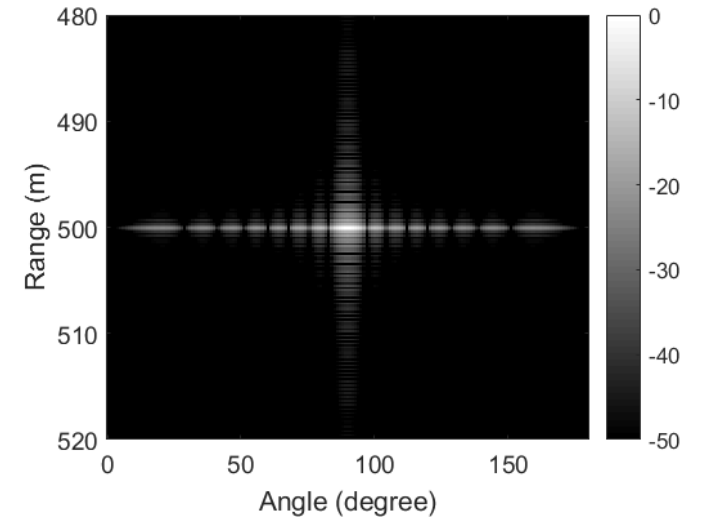
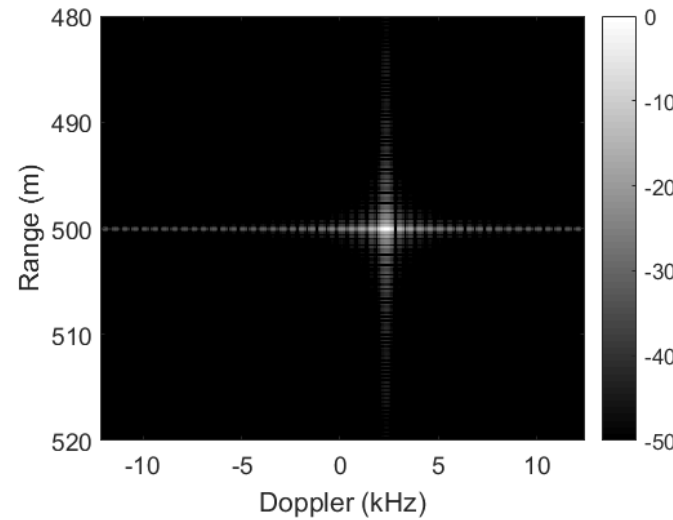

Target PSF of DDMA waveform

Code Division Multiple Access (CDMA) Waveform

- **Code Division Multiple Access (CDMA) MIMO waveform** means the signals transmitted by different antennas are modulated by different sets of **orthogonal phase codes**, either in **fast-time (i.e., intrapulse modulation)** or in **slow-time (i.e., interpulse modulation)**, so that the transmitted signals can be decoded/separated in radar receiver.
- Strictly speaking, the CDMA MIMO waveforms can just approximately satisfy the orthogonality requirement, since the exact orthogonal code sequence with ideal auto- and cross-correlation properties does not exist.

Fast-Time CDMA Waveform

Fast-time CDMA waveform: the phases of pulse signals transmitted by different antenna are modulated by a set of code sequences which are orthogonal to each other within each pulse (\rightarrow high range sidelobes), while the phase coding modulation from pulse to pulse remains the same.

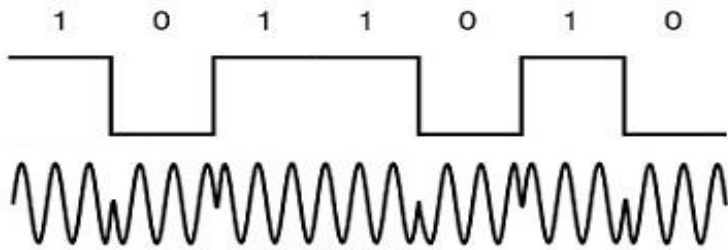

Example: Cyclic Algorithm New (CAN)* MIMO code

$$N = B \cdot T_p = 500$$

* H. He, P. Stoica, J. Li, "Designing unimodular sequence sets with good correlations – Including an application to MIMO radar", *IEEE Transactions on Signal Processing*, Vol.57, No.11, pp.4391-4405, Nov 2009

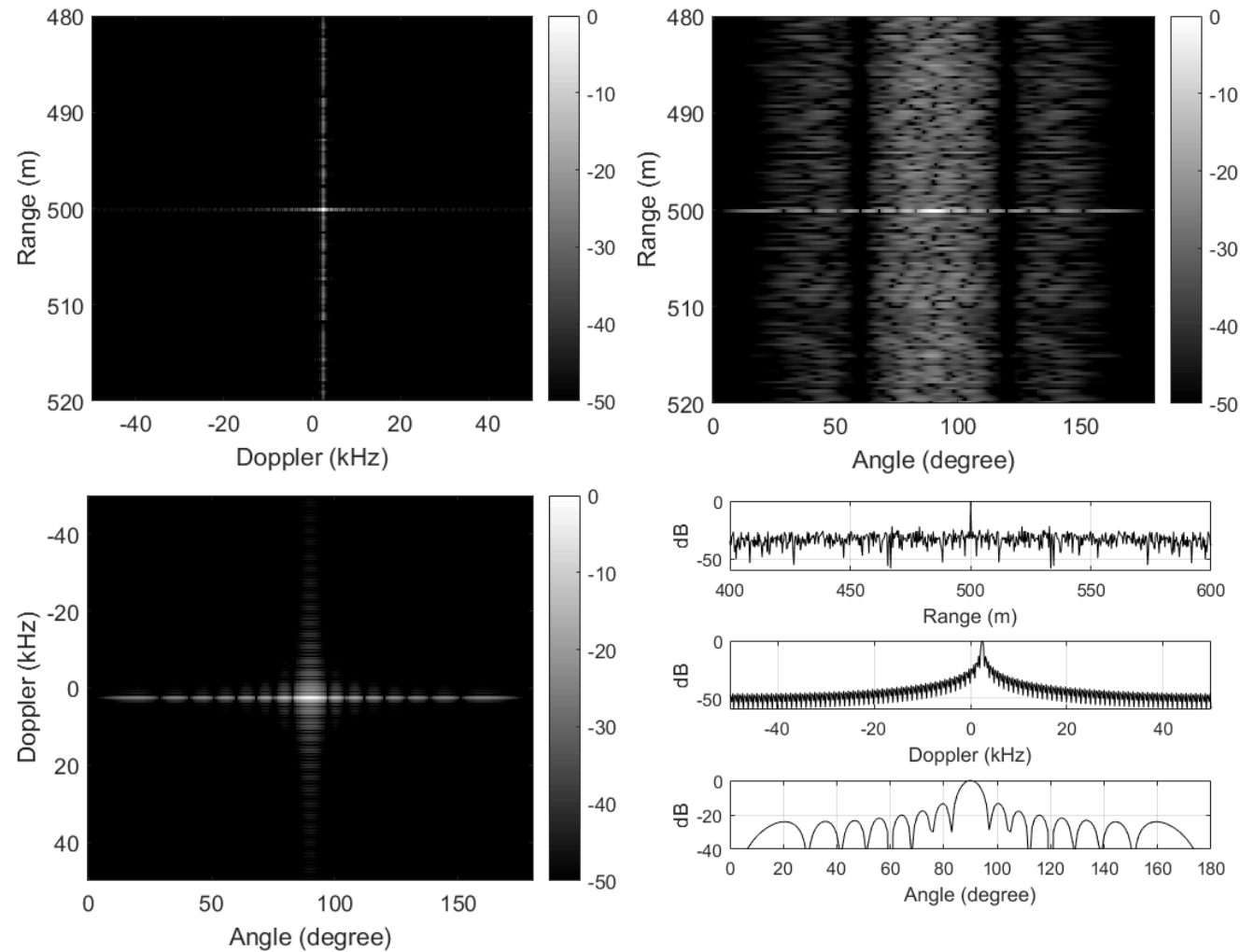

Target PSF of fast-time CDMA waveform

Slow-Time CDMA Waveform

Slow-time CDMA waveform: phase codes are used to modulate the initial phases of the signals from pulse to pulse, and the orthogonality of different transmitted signals are realized across the whole pulse train (→ **high Doppler sidelobes, 2D joint processing for Doppler and beamforming is required**).

Example: Cyclic Algorithm New (CAN)* MIMO code in 500 pulses.

* H. He, P. Stoica, J. Li, "Designing unimodular sequence sets with good correlations – Including an application to MIMO radar", *IEEE Transactions on Signal Processing*, Vol.57, No.11, pp.4391-4405, Nov 2009

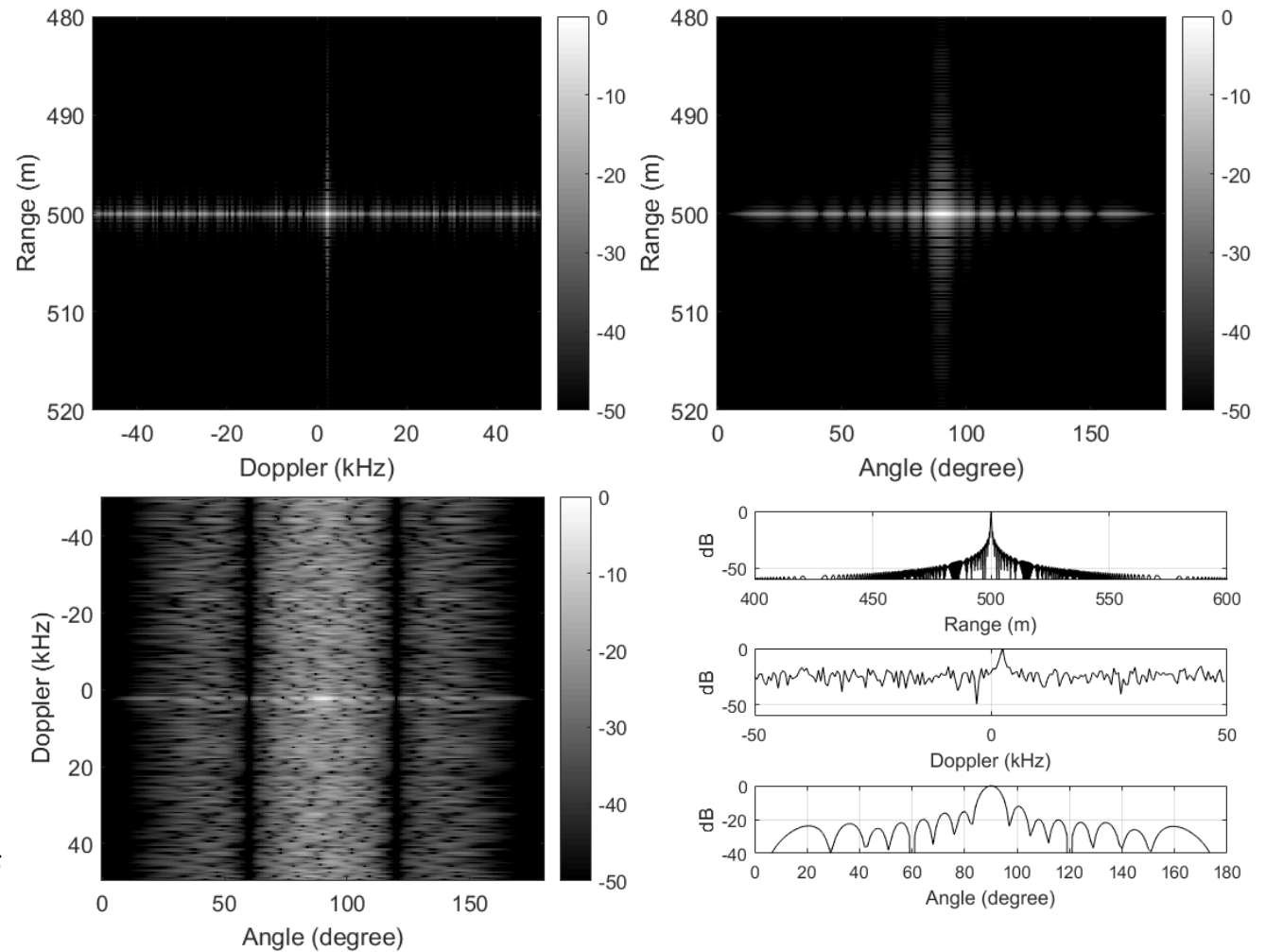

Target PSF of slow-time CDMA waveform

Hadamard Coding Waveform

- **Hadamard coding waveform:** the initial phases of N_e successive pulses of N_e transmit antennas are modulated by a N_e -by- N_e Hadamard matrix. At the receive side, the decoding is performed by multiplying the N_e -by- N_e Hadamard matrix to the received N_e successive pulse signals.
- Thus, effectively the unambiguous Doppler range are reduced by N_e times (**exactly same as the DDMA waveform**). It is **only applicable to low frequency radar with enough PRF tolerance**. The waveform orthogonality is sensitive to the Doppler frequency of fast moving targets.

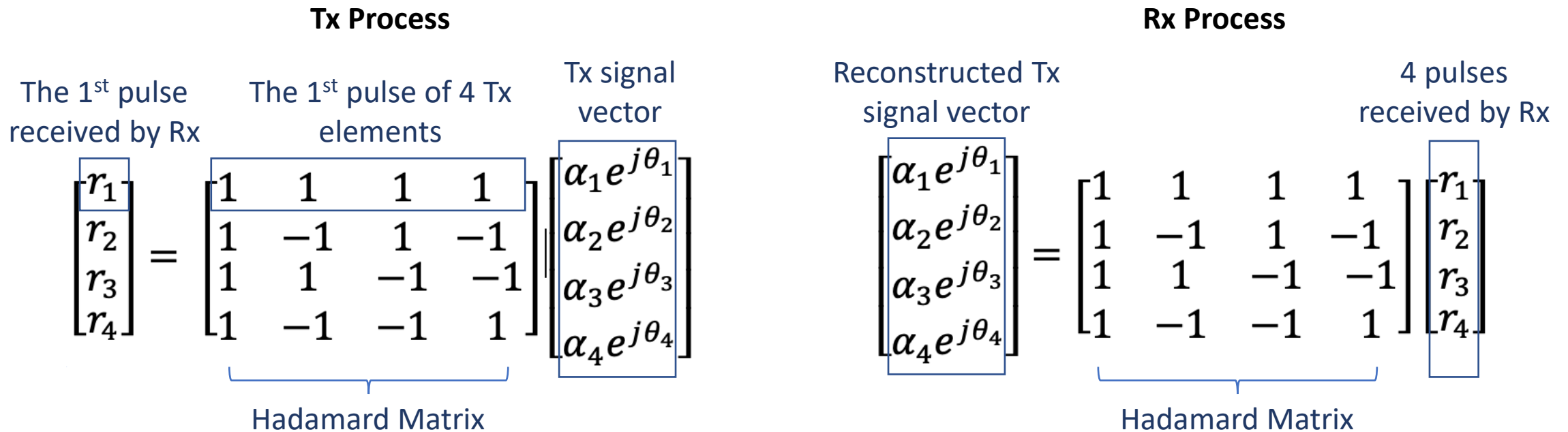

Hadamard Coding Waveform

The instantaneous beam patterns of Hadamard coding waveform for 2, 4 and 8 Tx

$$\mathbf{H}_2 = \begin{bmatrix} 1 & 1 \\ 1 & -1 \end{bmatrix}$$

$$\mathbf{H}_4 = \begin{bmatrix} 1 & 1 & 1 & 1 \\ 1 & -1 & 1 & -1 \\ 1 & 1 & -1 & -1 \\ 1 & -1 & -1 & 1 \end{bmatrix}$$

$$\mathbf{H}_8 = \begin{bmatrix} 1 & 1 & 1 & 1 & 1 & 1 & 1 & 1 \\ 1 & -1 & 1 & -1 & 1 & -1 & 1 & -1 \\ 1 & 1 & -1 & -1 & 1 & 1 & -1 & -1 \\ 1 & -1 & -1 & 1 & 1 & -1 & -1 & 1 \\ 1 & 1 & 1 & 1 & -1 & -1 & -1 & -1 \\ 1 & -1 & 1 & -1 & -1 & 1 & -1 & 1 \\ 1 & 1 & -1 & -1 & -1 & -1 & 1 & 1 \\ 1 & -1 & -1 & 1 & -1 & 1 & 1 & -1 \end{bmatrix}$$

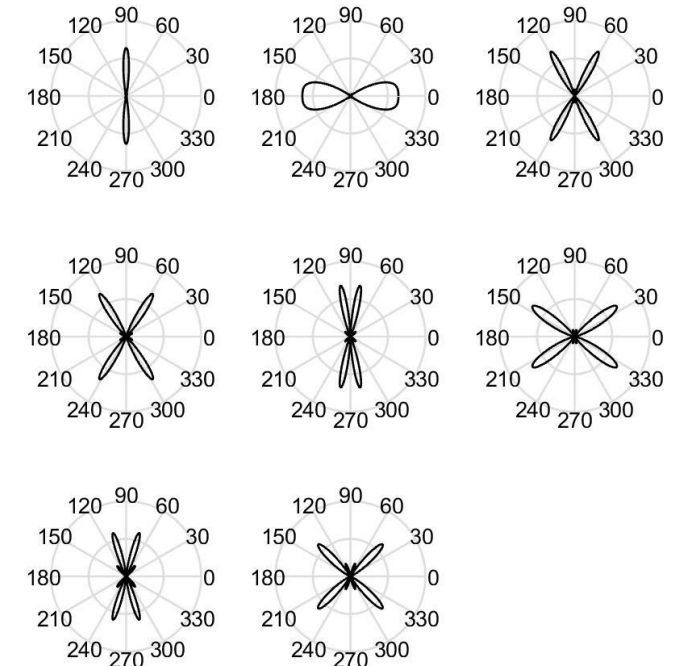
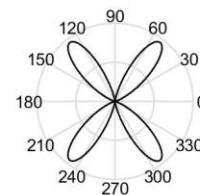
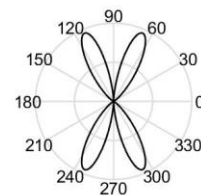
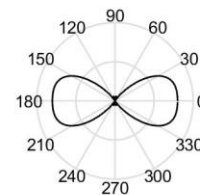
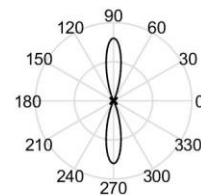
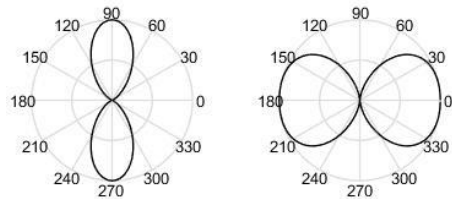

ARES PUBLIC

Frequency Division Multiple Access (FDMA) Waveform

- **Frequency Division Multiple Access (FDMA) MIMO waveform** means the signals transmitted by different antennas are modulated by different carrier frequencies, which is also called “orthogonal spatial-frequency coding” in some literatures
- Similar to the CDMA waveform, the FDMA waveform can also be implemented in either **fast-time (i.e., intrapulse frequency modulation)** or **slow-time (i.e., interpulse frequency modulation)**.

Fast-Time FDMA Waveform

Regular fast-time FDMA waveform (4 Tx)

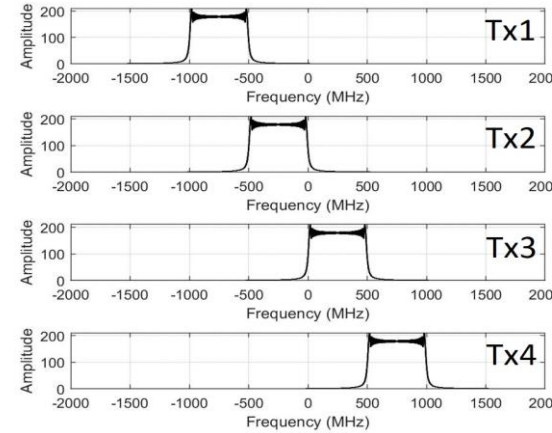
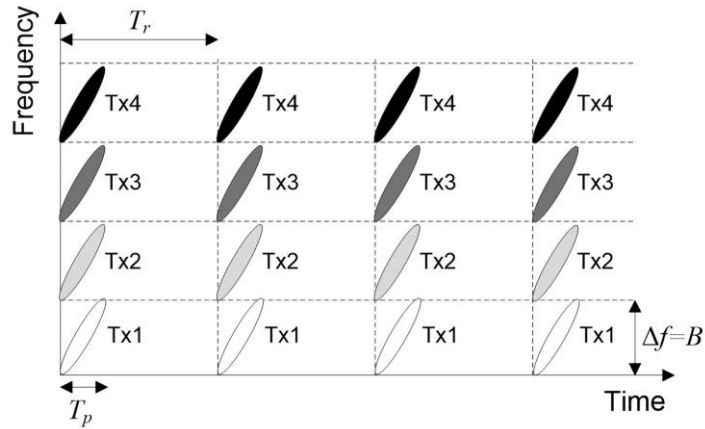

Strong range-angle coupling!

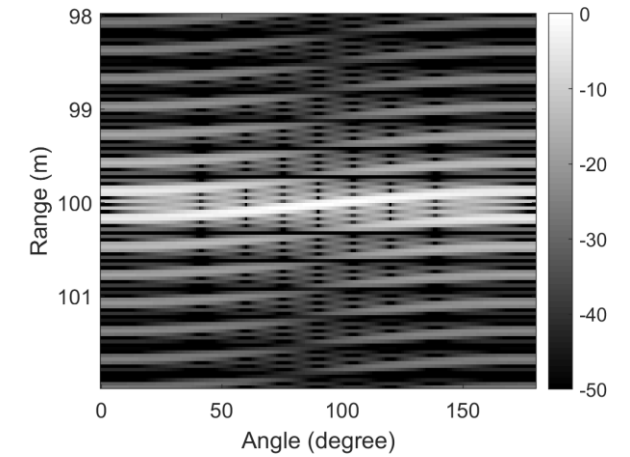

Randomized fast-time FDMA waveform (4 Tx)

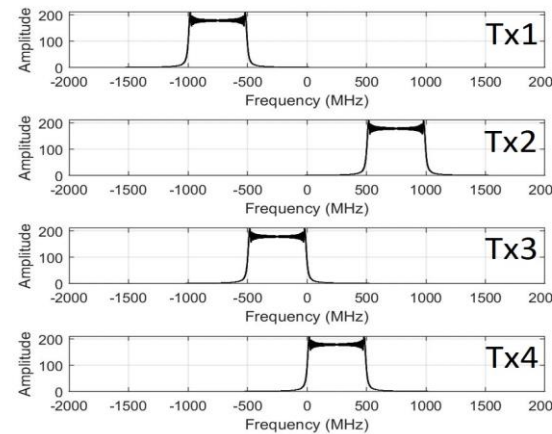
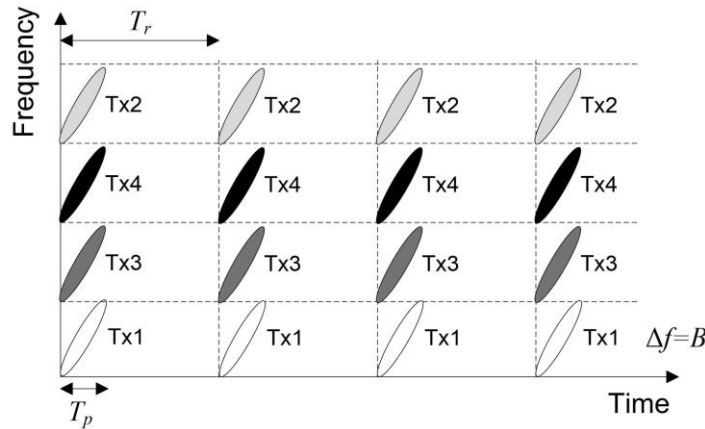

Range-angle coupling alleviated

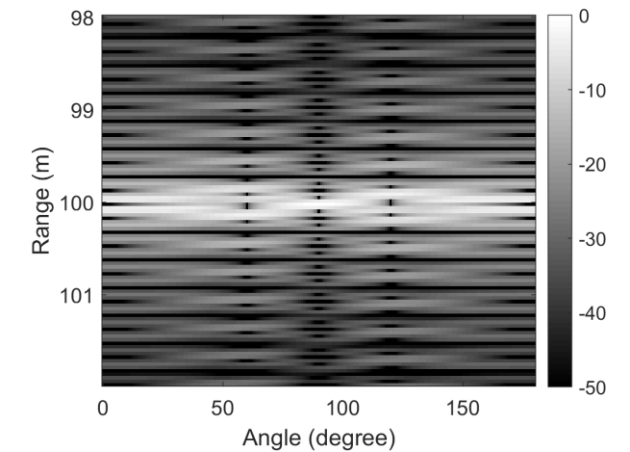

Fast-Time FDMA Waveform

Example: The first MIMO radar in the world - RIAS radar (ONERA, France)



ONERA mock up (1987)

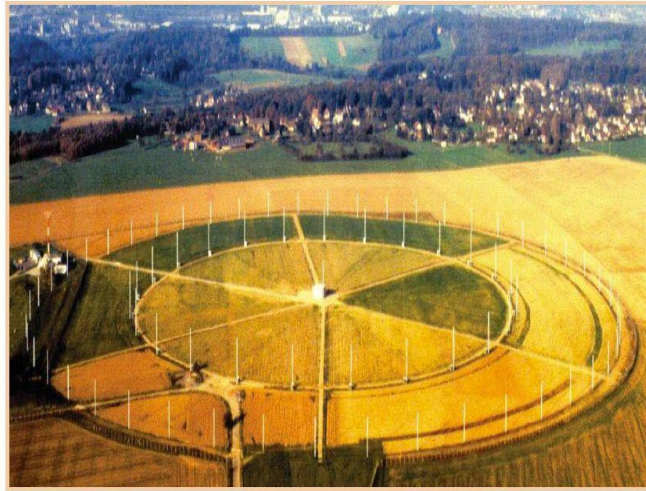

Thales demonstrator (1990)

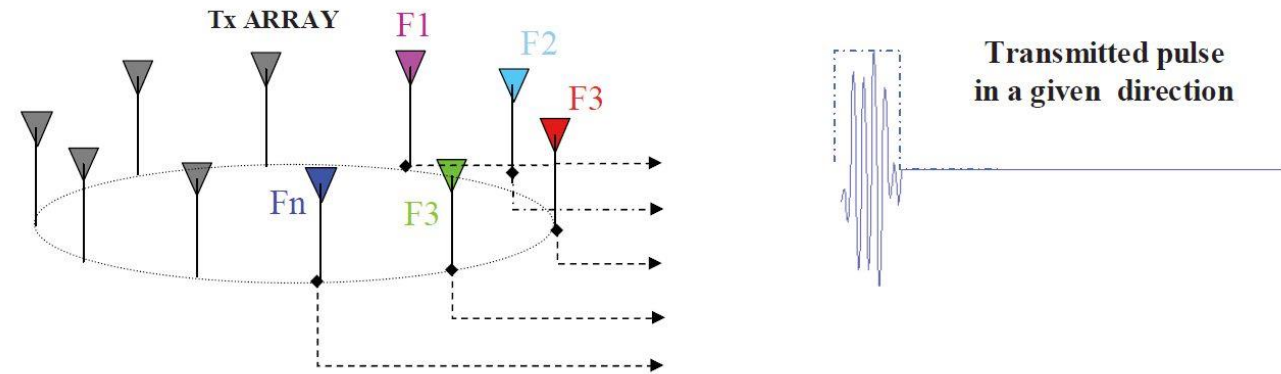

[Ref] J. Dorey, G. Gamier, G. Auvray, "RIAS - synthetic impulse and antenna radar", 1989 International Conference on Radar, Paris, pp.556-562, 1989

- Not applicable for GMTI radar (clutter de-correlates for different waveforms)
- Only applicable to large number of Tx antennas. Proper optimization is required to reduce the sidelobes

Slow-Time FDMA Waveform

Slow-time FDMA waveform extends the frequency coding across the pulse train, and each antenna transmits different carrier frequencies at different pulses. In this way the waveform DoF are greatly increased and low sidelobes are easier to achieve. Therefore, the **slow-time FDMA waveform can be used for the MIMO radar with only a few antennas.**

Discrete frequency coding LFM (DFC-LFM) waveform*

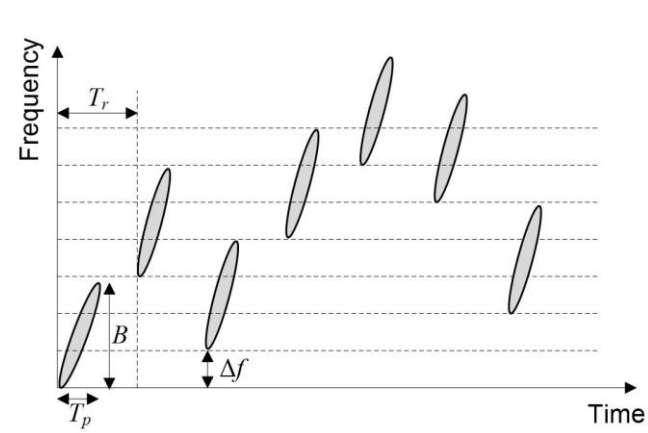
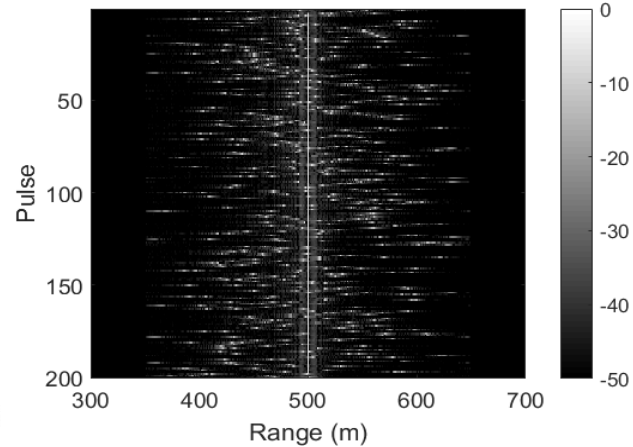

Illustration of slow-time FDMA waveform transmitted by one antenna



Range compressed signal received by one antenna

The range resolution of DFC-LFM waveform is determined by $\max[N\Delta f, B]$, which is smaller than the total occupied bandwidth $B+(N-1)\Delta f$.

* B. Liu, "Orthogonal discrete frequency-coding waveform set design with minimized autocorrelation sidelobes", *IEEE Trans. on Aerospace and Electronic Systems*, Vol.45, No.4, pp.1650-1657, Oct. 2009

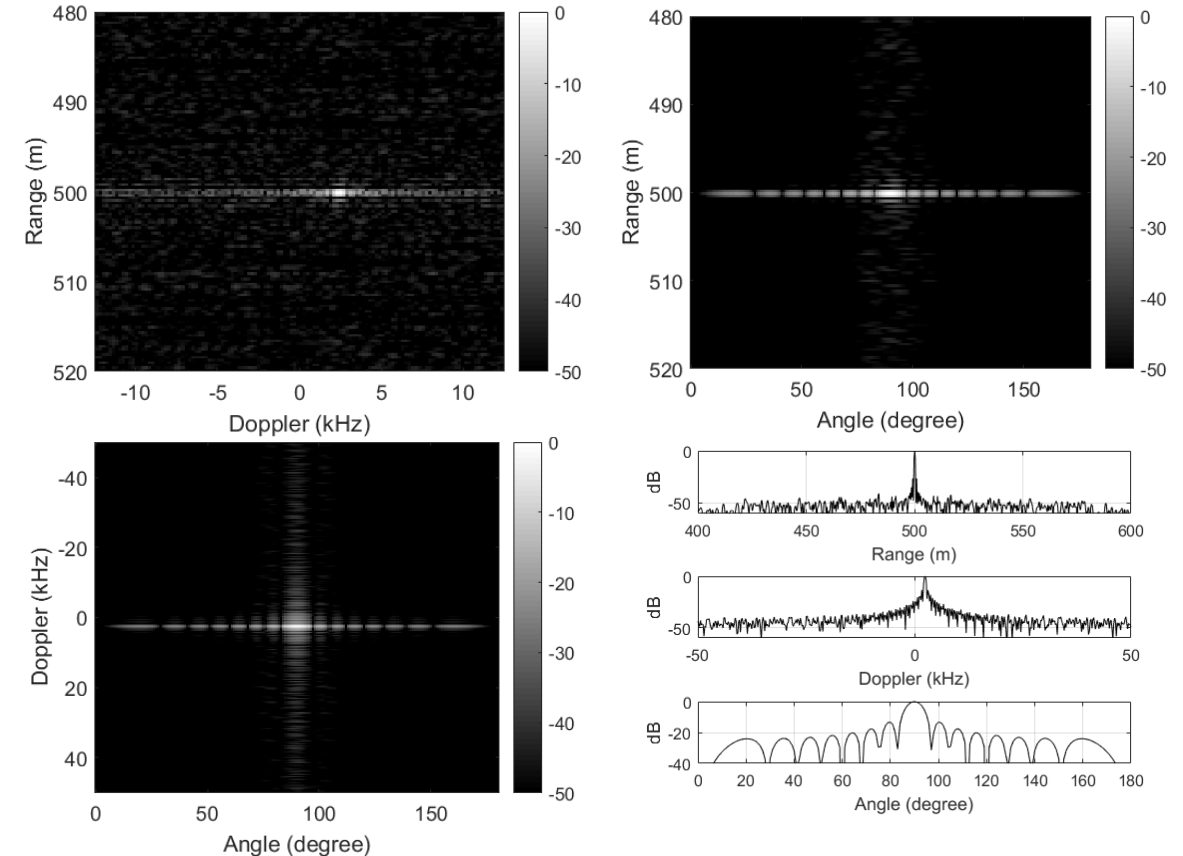

Target PSF of slow-time CDMA waveform

Circulating Waveform

Circulating MIMO waveform means the waveform (with any modulation) transmitted by each antenna is a **time-circulating copy of the same signal**, where the circulating step should be equal to $1/B$, B is the waveform bandwidth, to satisfy the orthogonality. **The range resolution is degraded (N_e times poorer), but the range sidelobe level is greatly reduced.**

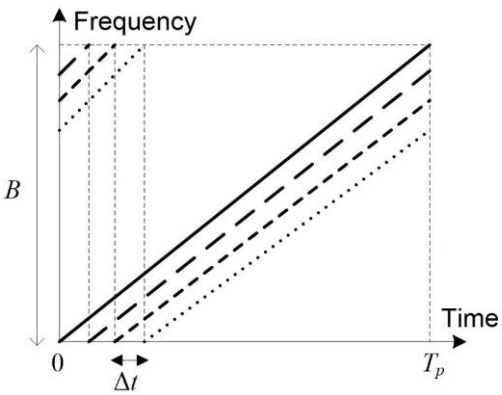

— Tx1
 - - Tx2
 - · Tx3
 ··· Tx4
 $\Delta t = \frac{1}{B}$

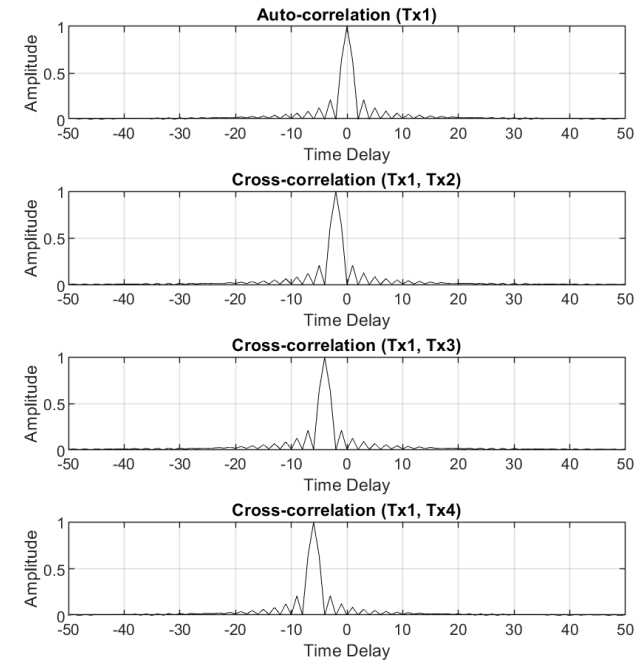

Auto/cross-correlations of the circulating LFM MIMO waveform

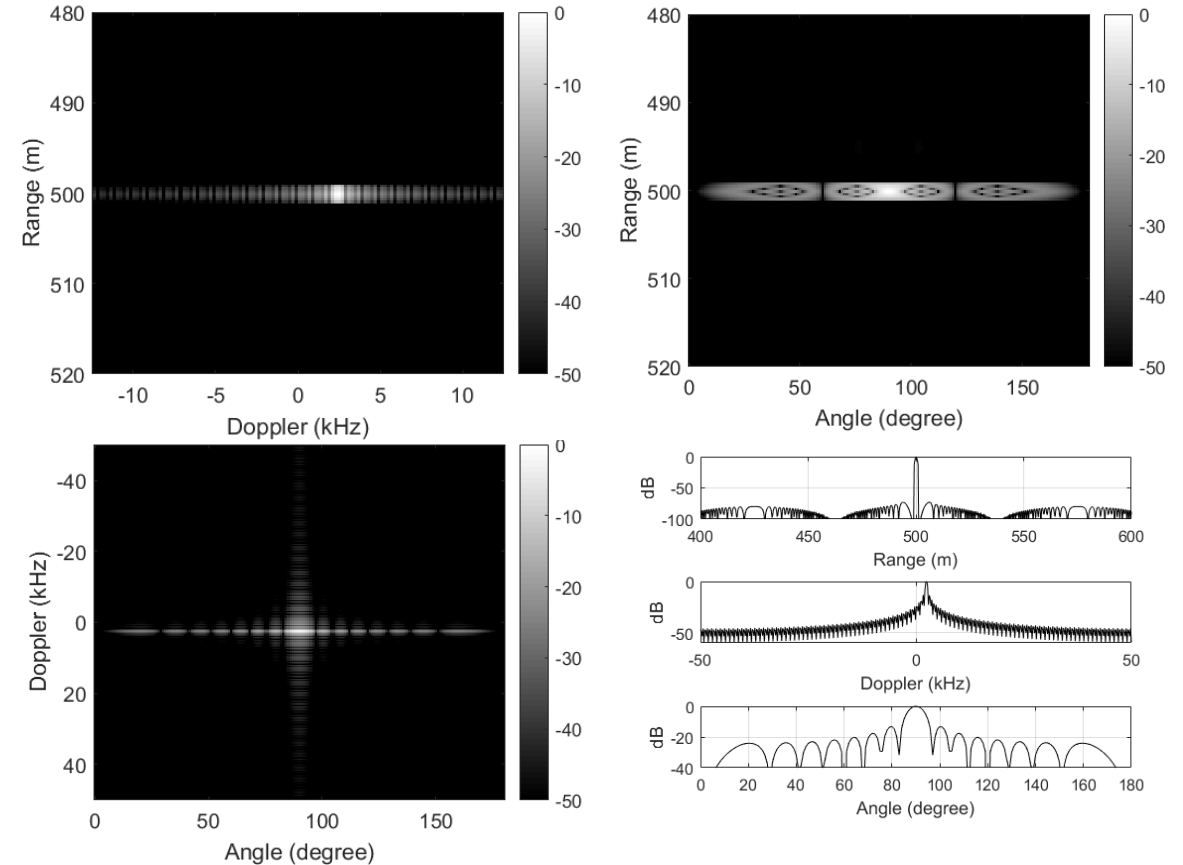

Target PSF of circulating waveform

Illustration of circulating LFM MIMO waveform

PSF Comparison for Various MIMO Radar Waveforms

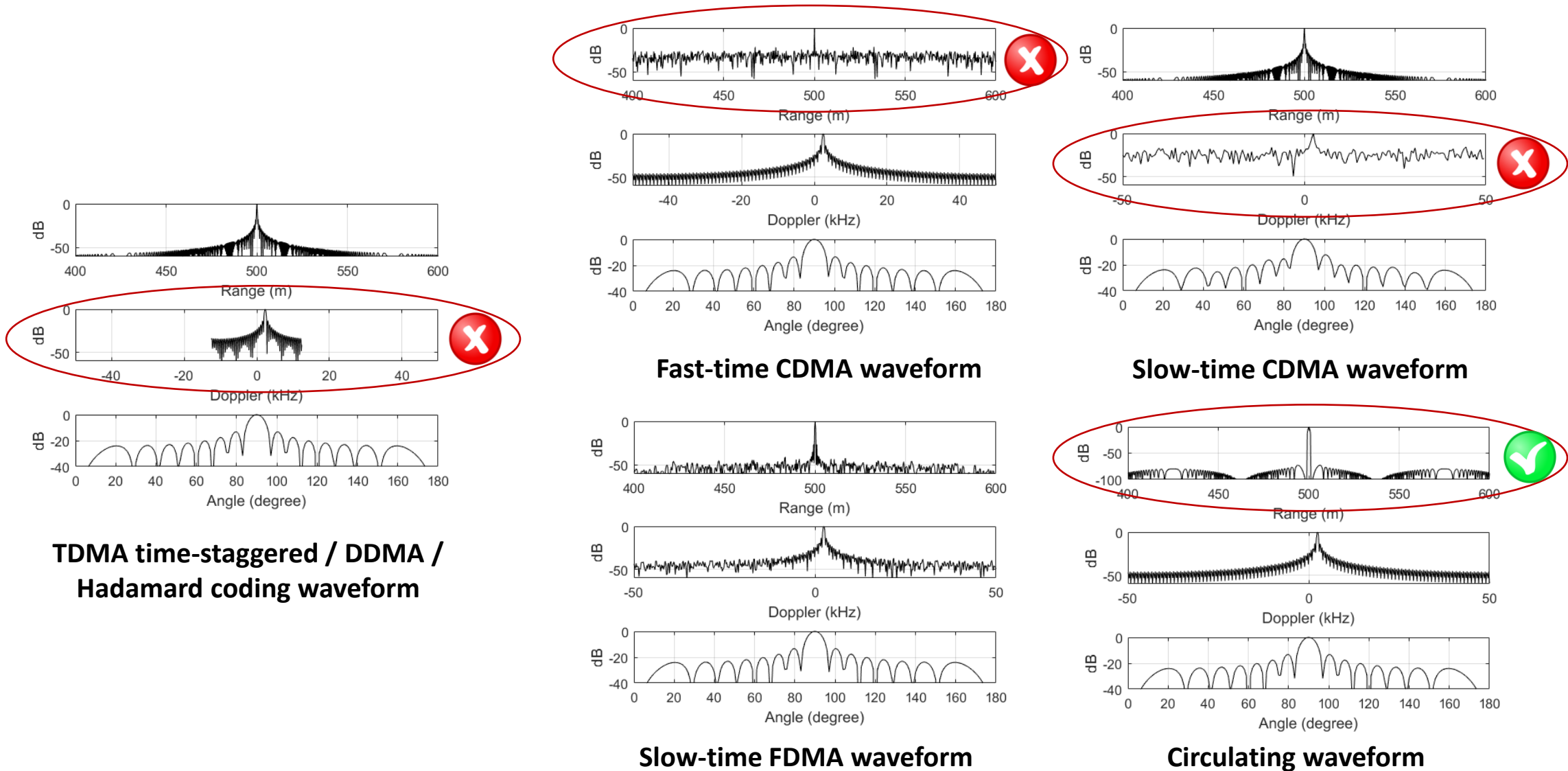

Summary of MIMO Radar Waveforms

MIMO Waveforms	Advantages	Disadvantages	Suitable Applications
TDMA - Alternative Transmission	Good orthogonality Low range / Doppler sidelobes	Loss of transmitting efficiency	Short-range radar with low transmitting power
TDMA - Staggered LFM CW	Good orthogonality Low range / Doppler sidelobes	Reduced Doppler unambiguity range	Low-frequency radar (e.g., HF-OTHR), or microwave radar for short range detection
DDMA	Good orthogonality Low range / Doppler sidelobes	Reduced Doppler unambiguity range	Low-frequency radar (e.g., HF-OTHR), or short-range microwave radar
Fast-time CDMA	Approximate orthogonality Low Doppler sidelobes	High range sidelobes	All
Slow-time CDMA	Approximate orthogonality Low range sidelobes	High Doppler sidelobes	All
Hadamard Coding	Good orthogonality (only for slow moving targets); Low range / Doppler sidelobes	Reduced Doppler unambiguity range; Sensitive to very fast-moving targets	Low-frequency radar for slow moving target detection
Fast-time FDMA	Good orthogonality	High range sidelobes	Large MIMO radar with many transmitting antennas
Slow-time FDMA	Good orthogonality	Moderate range / Doppler sidelobes Reduced range resolution	All
Circulating LFM	Good orthogonality; Ultra-low range sidelobes; Low Doppler sidelobes	Reduced range resolution	All

Summary of MIMO Radar Waveforms

Ideal orthogonal MIMO waveform does not exist.

There is no free lunch!

We have to sacrifice some performance when choosing a MIMO waveform.

Examples of MIMO Radar Demonstrations

Radar System	Country	Year	MIMO Waveform	Reference
Synthetic impulse and antenna radar (RIAS) for air surveillance	France	1989	Fast-time FDMA	J. Dorey, G. Gamier, G. Auvray, "RIAS - synthetic impulse and antenna radar", 1989 International Conference on Radar, Paris, pp.556-562, 1989
HF surface wave over-the-horizon radar	France	2015	Not mentioned	F. Jangal, M. Menelle, "French HFSWR contribution to the European integrated maritime surveillance system I2C", 2015 IET Radar Conference, Hangzhou, China, pp.1566-1570, Oct 2015
HF surface wave over-the-horizon radar	Canada	2015	Slow-time CDMA	A. Ponsford, R. McKerracher, Z. Ding, P. Moo, D. Yee, "Towards a cognitive radar: Canada's third-generation high frequency surface wave radar (HFSWR) for surveillance of the 200 nautical mile exclusive economic zone", <i>Sensors</i> , 17(7), 1588, 2017
HF sky-wave radar	Australia	2008	TDMA (Time-staggered LFM CW)	G.J. Frazer, Y.I. Abramovich, B.A. Johnson, F.C. Robey, "Recent results in MIMO over-the-horizon radar", 2008 IEEE Radar Conference, Rome, Italy, pp.789-794, May 2008. G.J. Frazer, Y.I. Abramovich, B.A. Johnson, "Multiple-input multiple-output over-the-horizon radar: Experimental results", <i>IET Radar, Sonar & Navigation</i> Vol.3, No.4, pp.290-303, Sep 2009
Airborne GMTI radar	United States	2010	DDMA	J. Kantor, S.K. Davis, "Airborne GMTI using MIMO techniques", 2010 IEEE International Radar Conference, Washington D.C., US, pp.1344-1349, May 2010
Atmospheric Radar	Japan	2023	DDMA	T. Matsuda, H. Hashiguchi, "DDMA-MIMO observations with the MU radar: validation by measuring a beam broadening effect", <i>IEEE Journal of Selected Topics in Applied Earth Observations and Remote Sensing</i> , pp.(99):1-9, January 2023
Ground-based imaging radar	Germany	2010	TDMA (Alternative transmission)	J. Klare, O. Saalman, H. Wilden, A.R. Brenner, "First Experimental Results with the Imaging MIMO Radar MIRA-CLE X", The 8th European Conference on Synthetic Aperture Radar, Aachen, Germany, pp.374-377, Jun 2010

Example – Implementing MIMO Waveform in mmWave Automotive Radar

ARES PUBLIC



mmWave Automotive Radar

<https://www.mwrf.com/technologies/systems/article/21848960/the-startups-trying-to-revamp-automotive-radar>

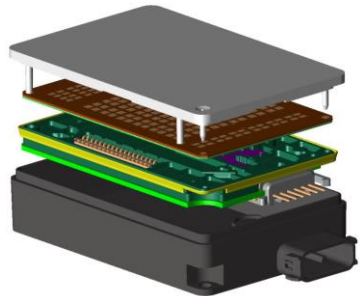
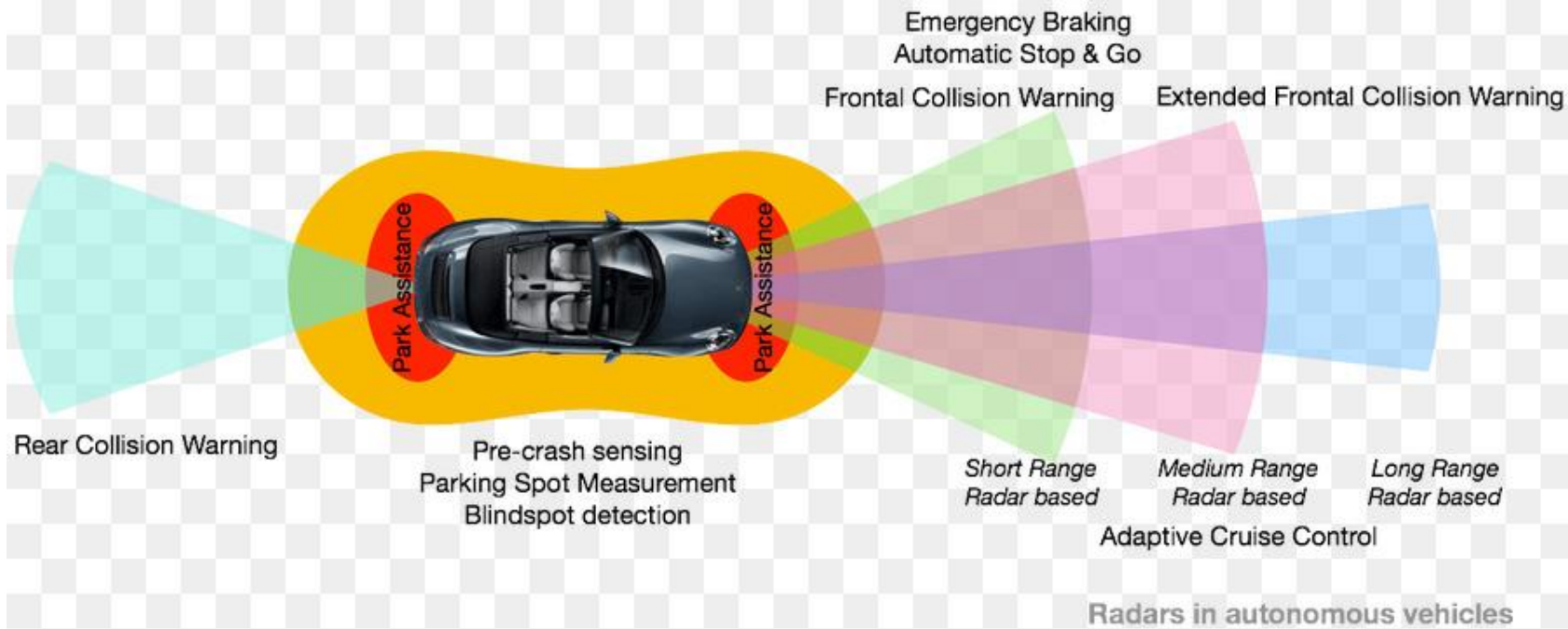

ARES PUBLIC

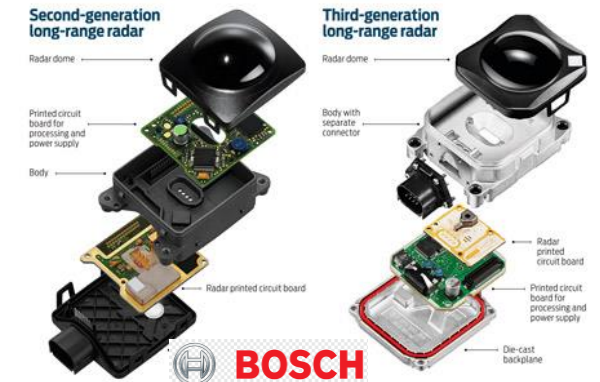

Implementing MIMO in mmWave Automotive Radar

AWR2944 Single-Chip 76-81GHz FMCW Radar Sensor

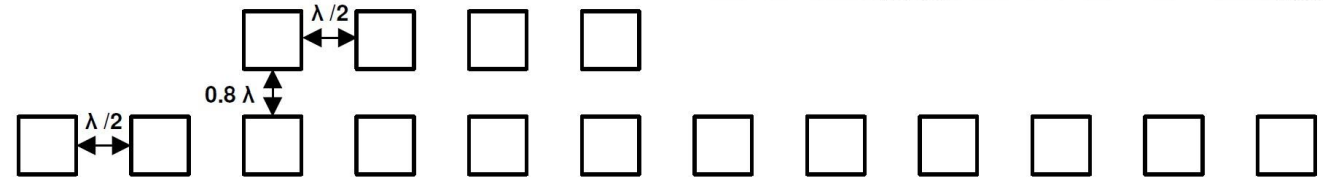
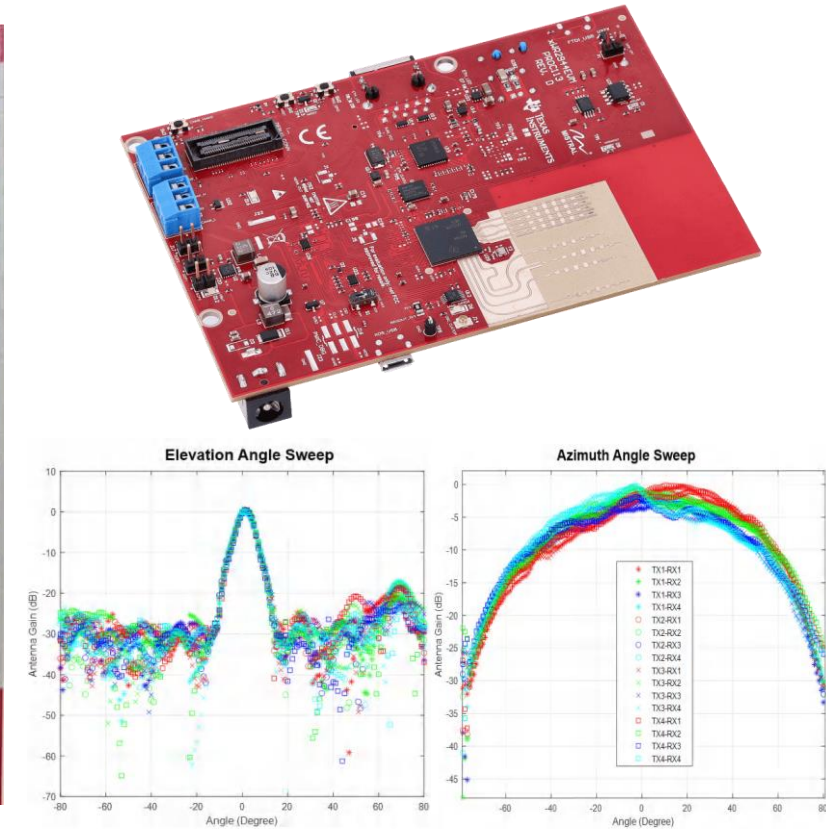
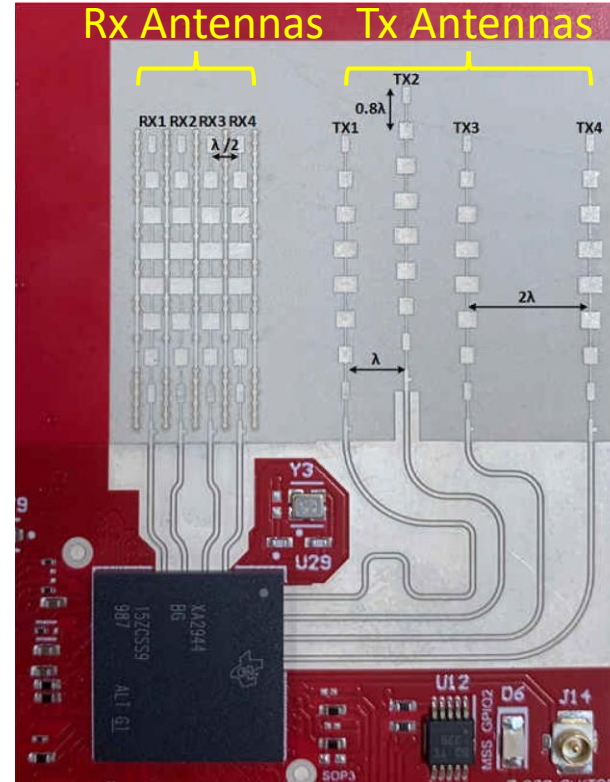
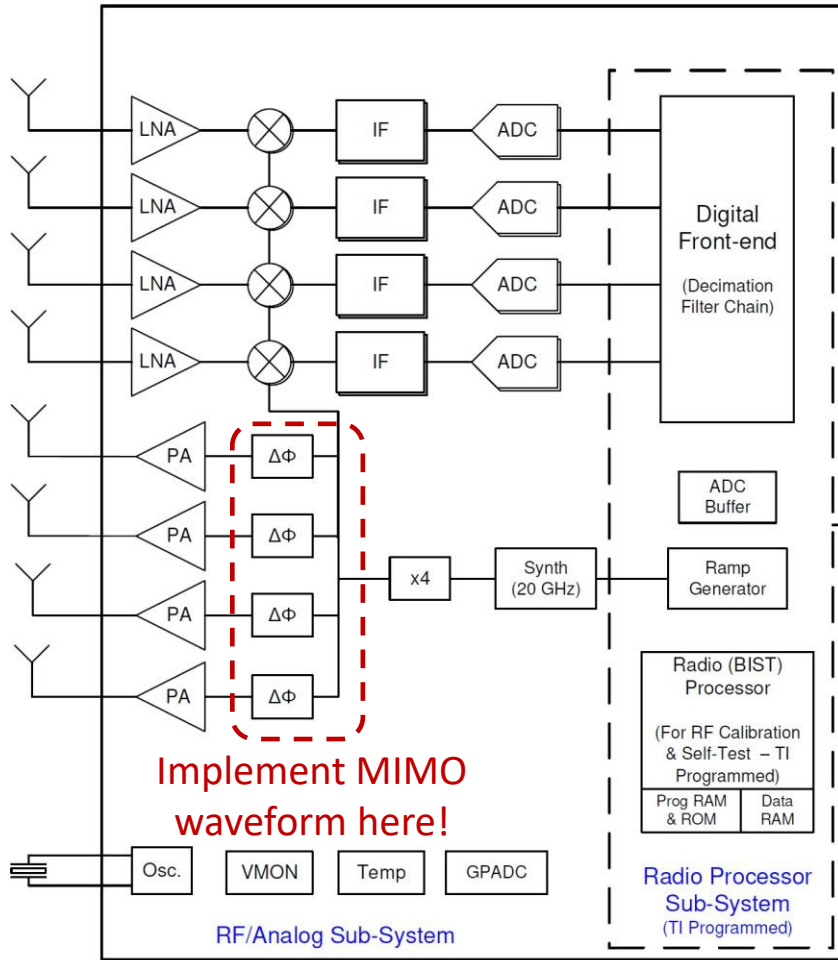

Implementing MIMO in mmWave Automotive Radar

AWR2944 Single-Chip 76- and 81-GHz FMCW Radar Sensor

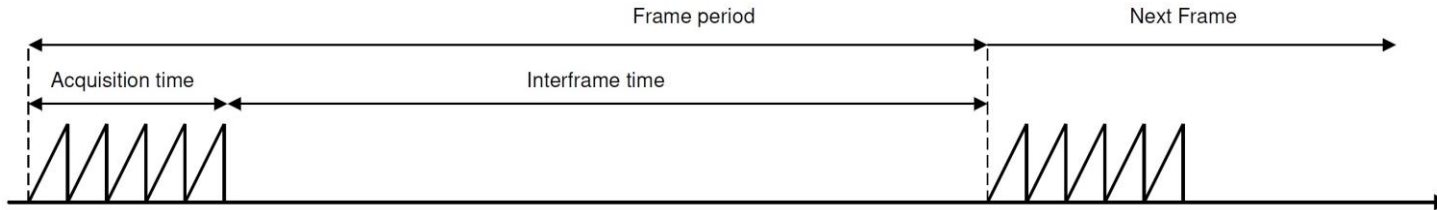
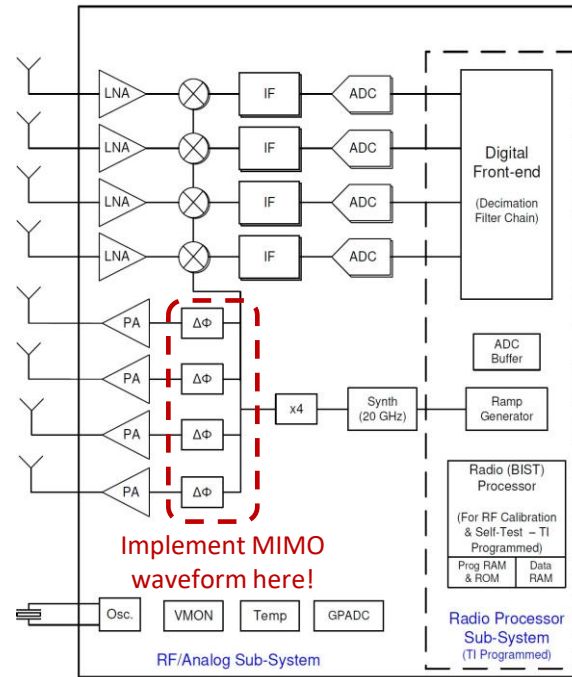

Table 2-1. Chirp Configuration

PARAMETER	CONFIGURATION
Idle time (μs)	5
ADC start time (μs)	5
Ramp end time (μs)	18.83
Number of ADC samples	384
Frequency slope (MHz/ μs)	8.883
MIMO (1 \rightarrow yes)	1
Number of chirps per profile	768
Effective chirp time (μs)	23.83
Bandwidth (MHz)	114
Frame length (ms)	250

Table 2-2. System Performance Parameter

PARAMETER	SPECIFICATIONS
Range resolution (m)	1.3
Maximum distance (m)	200
Native maximum velocity (kmph)	140



DDMA: If there are N_e transmitters, each transmitter is modulated with phase $\omega_k = 2\pi(k-1)/N_e$, k is the pulse index.

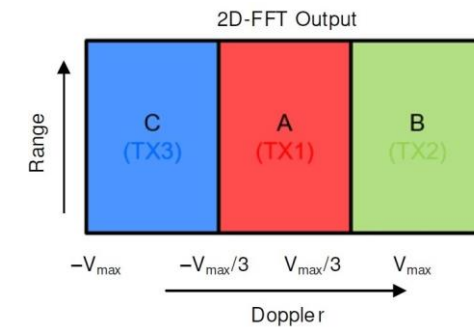
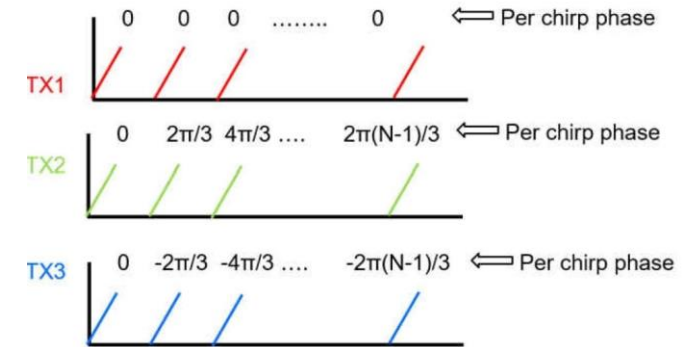

* Hadamard coding and slow-time CDMA waveforms can also be implemented.

Design Guide: TIDEP-01027, "High-End Corner Radar Reference Design", Texas Instruments

ARES PUBLIC

Field Trial Results



Motorbike detection with AWR2944 Evaluation Module

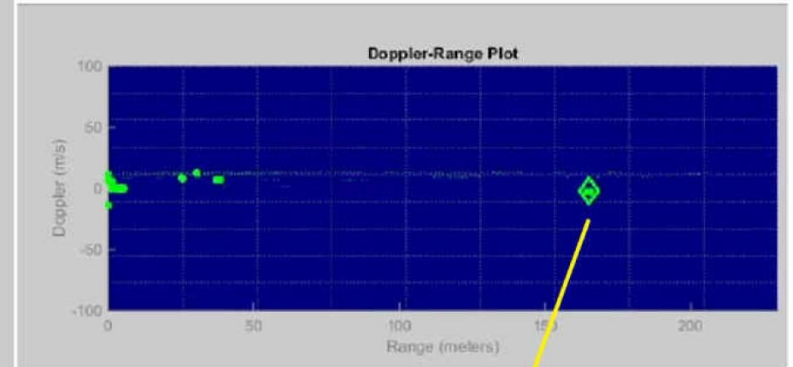
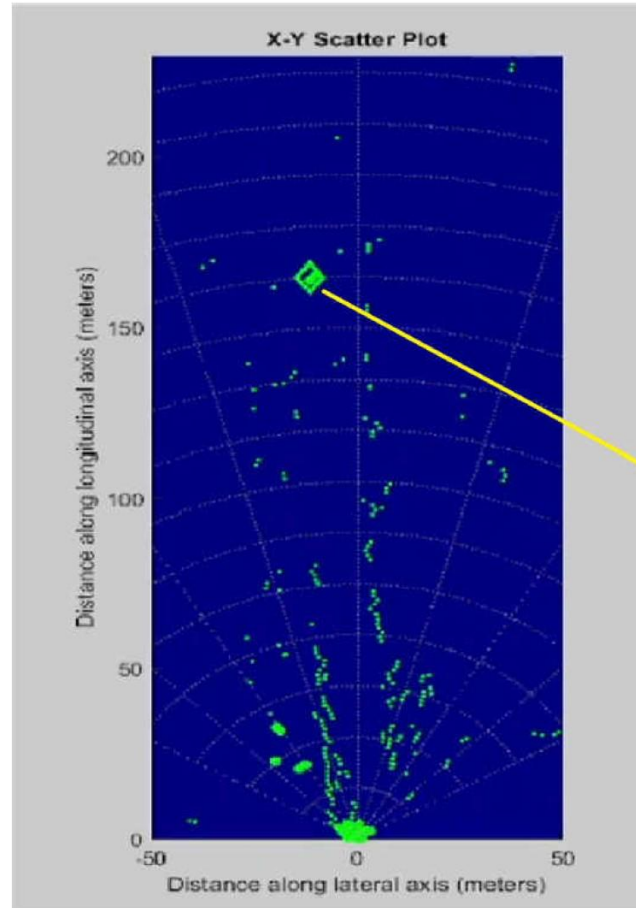
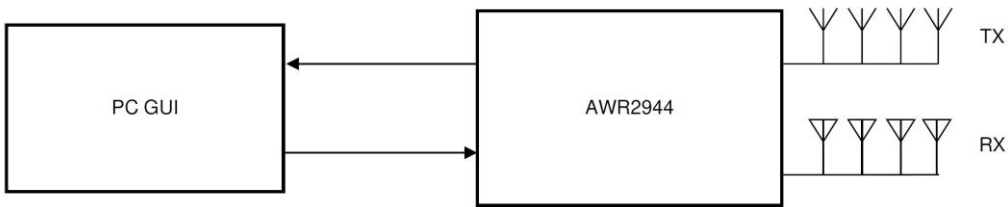

Design Guide: TIDEP-01027, "High-End Corner Radar Reference Design", Texas Instruments

ARES PUBLIC

Form Larger Aperture Using Cascaded mmWave Radar Sensor

AWR2243 Four-Device Cascade Radar RF Radar Board

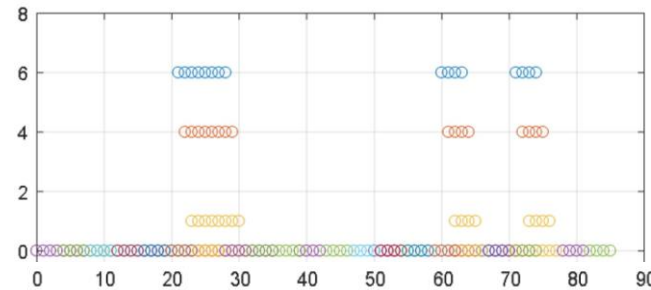
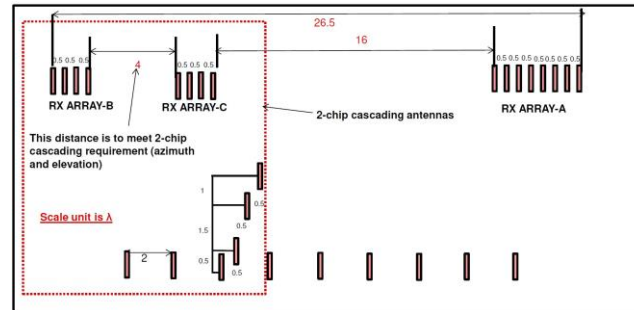
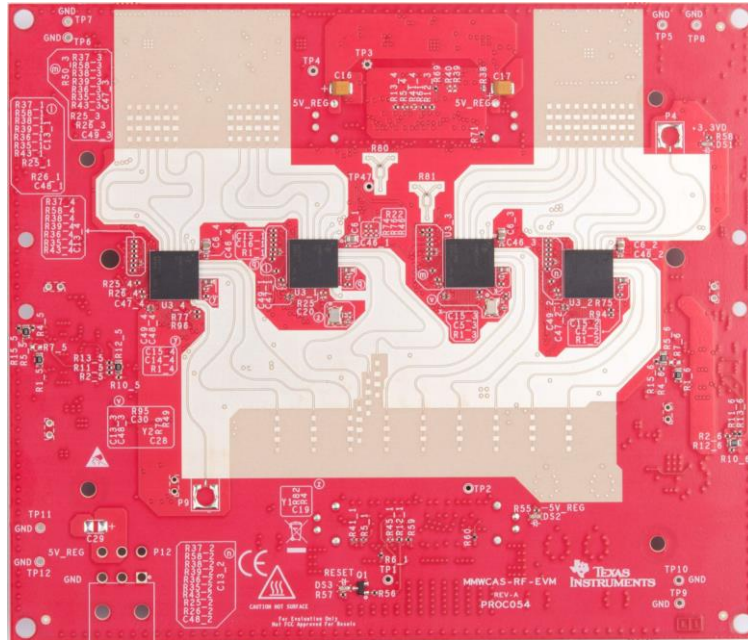

Potentially, a distributed large-aperture conformal MIMO array can be formed to significantly enhance the angular resolution of automotive radar.

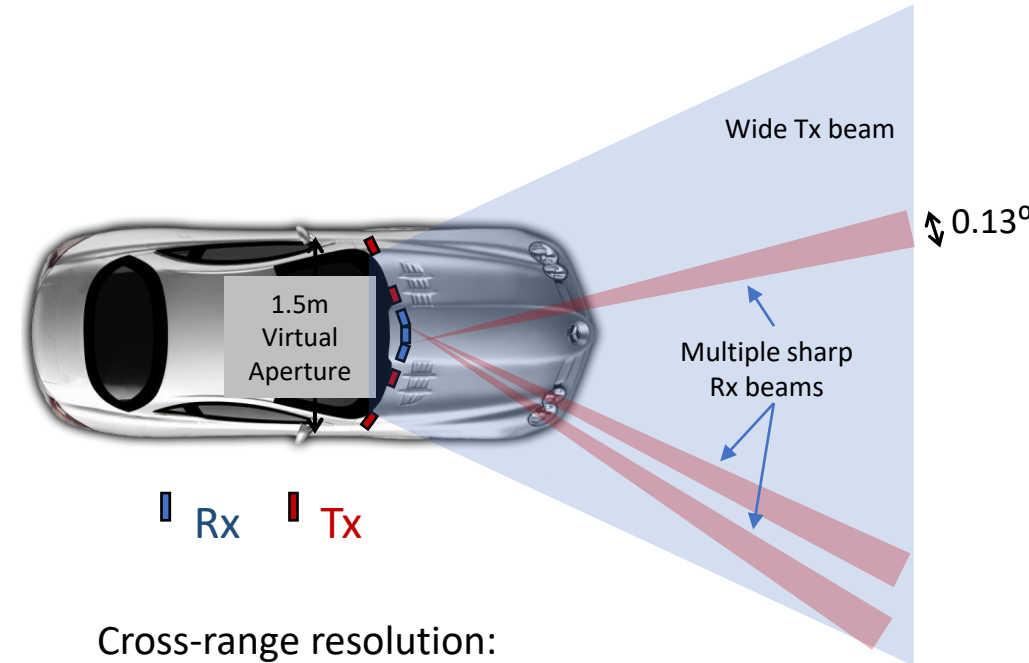

- 4 x AWR2243 76-81GHz Radar SoC: Integrated VCO, LO distribution, PA, LNA, ADC, 3 TX and 4 RX Arm MCU R4 Controller
- 12 x TX and 16 x RX across all 4 AWR2243 devices
- Azimuth Array: 86 element virtual array – **enabling 1.4° angular resolution**
- Elevation Array: 4 element virtual array – enabling 18° angular resolution

Cross-range resolution:

- 4.6cm @ 20m
- 11.4cm @ 50m
- 22.8cm @ 100m

Design Guide TIDEP-01012 Imaging Radar Using Cascaded mmWave Sensor Reference Design, Texas Instruments

ARES PUBLIC



THANK YOU

www.a-star.edu.sg